



## Cast Iron Boilers

# KEYSTONE

## Oil-Fired Water Boilers

### SYSTEM FEATURES

- **High Efficiency** – The Keystone water boiler is capable of reaching as high as 86.4% efficiency as certified by test procedures prescribed by the US Department of Energy.
- **Cast Iron Sections and Push Nipples** – The Keystone's wet base designed heat exchanger is constructed of heavy-duty cast iron sections and sealed with cast iron push nipples.
- **Beckett Oil Burner** – The Keystone comes standard with the highly efficient Beckett AFG burner.
- **Tankless Heater Coil (optional)** – 5 gallon per minute tankless heater coil provides domestic hot water for your home needs. (Domestic hot water output varies upon BTU capacity of boiler)
- **Flame Inspection/Clean Out Port** – 2" cast iron teardrop provides easy access for flame inspection and accommodates snorkel vacuuming for cleaning.
- **Steel Jacket** – Finished in attractive gray enamel, the Keystone jacket is insulated to eliminate heat loss during off cycles.
- **American Made** – Pennco boilers are made in the United States by American craftsmen.



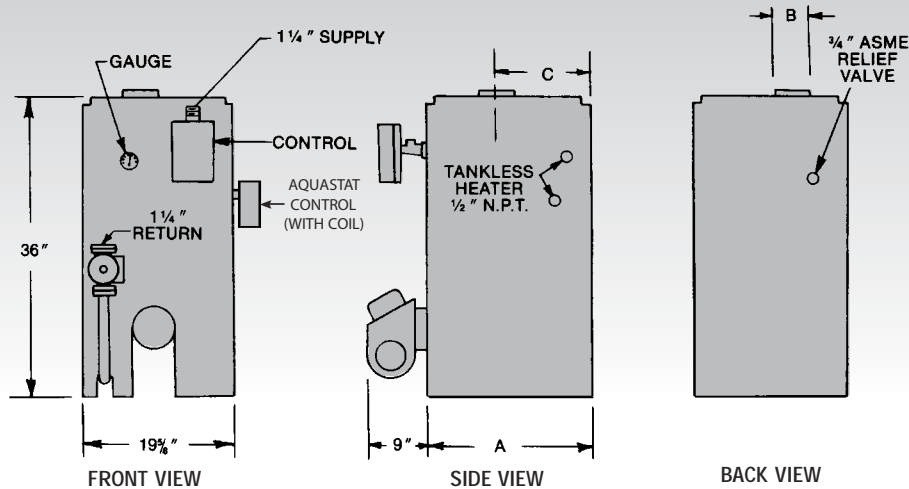

## KEYSTONE WATER



OIL-FIRED HOT-WATER BOILERS										RATINGS & CAPACITIES				
Model No. with Tankless Coil	Model No. without Tankless	No. of Sec.	Input * MBH	** Heating Capacity * MBH	Net I=B=R Rating * MBH	Firing Rate † GPH	Tankless Heater Capacity †† GPM	Chimney Size	DIMENSIONS (INCHES)			A.F.U.E. †††	Approx. Shipping Weight	
									A	B	C			
3K.60C	3K.60	3	84	74	64	.60	2.85	8x8x15	17 3/4	6	9 3/4	86.1	500	
3K.75C	3K.75	3	105	92	80	.75	3.00	8x8x15	17 3/4	6	9 3/4	85.6	500	
3K1.00C	3K1.00	3	140	120	104	1.00	3.25	8x8x15	17 3/4	6	9 3/4	84.4	500	
4K.90C	4K.90	4	126	111	97	.90	3.15	8x8x15	21	6	11 3/8	86.4	580	
4K1.25C	4K1.25	4	175	153	133	1.25	3.50	8x8x15	21	6	11 3/8	85.9	580	
4K1.50C	4K1.50	4	210	181	157	1.50	3.75	8x8x15	21	6	11 3/8	85.1	580	
5K1.20C	5K1.20	5	168	147	128	1.20	3.45	8x8x15	24 1/4	6	13	86.1	680	
5K1.75C	5K1.75	5	245	210	183	1.75	4.00	8x8x15	24 1/4	6	13	84.8	680	
5K2.00C	5K2.00	5	280	239	209	2.00	4.25	8x8x20	24 1/4	6	13	84.0	680	

\* MBH = 1,000 BTU PER HOUR    BTU = BRITISH THERMAL UNIT    †† GALLONS OF WATER PER MINUTE, HEATED FROM 40° TO 140°, WITH 200° BOILER WATER  
 \*\* HEATING CAPACITY BASED ON 13% CO<sub>2</sub> WITH A 0.02 I.W.C. DRAFT OVER TEMPERATURE, INTERMITTENT DRAW.  
 ††† ANNUAL FUEL UTILIZATION EFFICIENCY BASED UPON D.O.E. TEST PROCEDURE.  
 † GPH = GALLONS PER HOUR OIL AT 140,000 BTU PER GALLON    \* AS AN ENERGY STAR PARTNER, DUNKIRK HAS DETERMINED THAT THIS PRODUCT MEETS ENERGY STAR GUIDELINES FOR ENERGY EFFICIENCY.

### KEYSTONE WATER BOILER STANDARD EQUIPMENT

- Assembled boiler with insulated jacket
  - Combination high limit control and circulator relay, on boilers without optional tankless heater coil
  - Combination high limit control, low limit control and circulator relay, on boilers with optional tankless heater coil
  - Target wall (vacuum formed refractory ceramic fiber)
  - Combination pressure/ temperature gauge
  - Barometric draft control 6"
  - 1 1/4" Grundfos (or Taco) circulator pump (field mounted)
  - 3/4" boiler drain valve
  - 30 lb. ASME relief valve
  - Beckett AFG series oil burner equipped with nozzle, primary control, interrupted duty ignition, PSC motor and clean cut (solenoid) pump
- The ratings marked "Net I=B=R Ratings" indicate the amount of remaining heat input that can be used to heat the radiation or thermal units. The Net I=B=R Ratings shown are based on an allowance of 1.15 in accordance with the factors shown in the I=B=R Code as published by The Hydronics Institute.
- Selection of boiler size should be based upon "Net I=B=R RATING" being equal to or greater than the calculated heat loss of the building.
- The manufacturer should be consulted before selecting a boiler for installations having unusual piping and pick-up requirements. Specifications and dimensions are subject to change without notice.
- These boilers are constructed and hydrostatically tested for a maximum working pressure of 50 psi in accordance with A.S.M.E. (American Society of Mechanical Engineers) Boiler and Pressure Vessel Code Section IV Standards for cast iron boilers. They are capacity rated in accordance with the code of the Hydronics Institute.

