



## KSC IV Series

Oil-Fired Steam Boiler



Heat Shield Baffle

### Standard Equipment:

- Crated Cast-Iron Boiler
- Flush Jacket
- Swing-Out Burner Door
- Beckett Oil Burner
- Target Wall/Liner
- Honeywell Pressure Control
- Boiler Water Level Gauge Glass
- Steam Pressure Gauge
- Electronic Low Water Cut-Off
- ASME Relief Valve
- Drain Valve
- Wiring Harness
- Burner Electric Disconnect
- Supply Tapping (2")
- Return Tapping – 1 1/2"
- Skim Port

### Tankless Water Heater Option:

- Tankless Hot Water Coil
- Limit Control

The Pennco KSC IV Series features a patented protective heat shield baffle to protect the casting above the water line.

**Quality Heat Exchanger Design** – The KSC IV Series features a robust cast iron heat exchanger for longer boiler life. The sections are connected with cast iron push nipples, which expand and contract at the same rate as the sections ensuring a water tight seal. The KSC IV Series is available in four sizes from 106 MBH to 247 MBH.

**Efficiency** – The KSC IV Series provides an EnergyStar rated annual fuel utilization efficiency of 82% as certified by the US Department of Energy testing standards.

**Warranty** – The Pennco KSC IV comes with a Limited 10 Year Manufacturer's Warranty.

**Made in the USA.**

Pennco SILVER makes *Simple Comfort, Affordable.*

# KSC IV Series

## Oil-Fired Steam Boiler

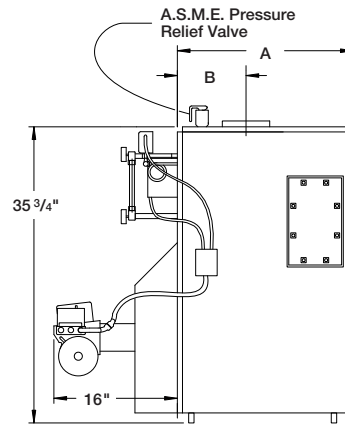

RIGHT SIDE VIEW

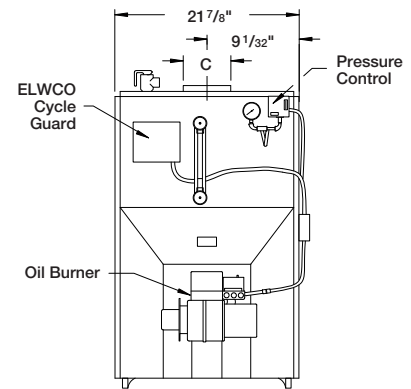

FRONT VIEW

### Specifications:

Model	AHRI Oil Burner Input <sup>(1)</sup>		Htg. Cap. MBH <sup>(4)</sup>	Net AHRI Ratings <sup>(3)</sup>		Min. Nat. Draft Chimney Size		Pump Press. PSI	Nozz Furn.	AFUE % <sup>(4)</sup>
	G.P.H.	MBH <sup>(2)</sup>		Steam MBH	Sq. Ft. Steam	Round	Square			
<b>WITHOUT TANKLESS</b>										
KSC-3090S	0.90	126	106	80	333	6"	8"x8"x15'	150	0.75-60°B	82.0%
KSC-4125S	1.25	175	147	110	458	6"	8"x8"x15'	140	1.10-60°B	82.0%
KSC-5185S	1.85	259	216	162	675	8"	8"x8"x15'	150	1.50-70°B	82.0%
KSC-6210S	2.10	294	247	185	771	8"	8"x8"x15'	145	1.75-70°B	82.0%
<b>WITH TANKLESS</b>										
KSC-3090ST	0.90	126	106	80	333	6"	8"x8"x15'	150	0.75-60°B	82.0%
KSC-4125ST	1.25	175	147	110	458	6"	8"x8"x15'	140	1.10-60°B	82.0%
KSC-5185ST	1.85	259	216	162	675	8"	8"x8"x15'	150	1.50-70°B	82.0%
KSC-6210ST	2.10	294	247	185	771	8"	8"x8"x15'	145	1.75-70°B	82.0%

- (1) Burner input is based on an oil heating value of 140,000 Btu/gal.
- (2) MBH = 1000 Btu per hour [Btu = British Thermal Unit].
- (3) Net AHRI Steam Ratings based on piping and pick-up allowance of 1.333. Consult manufacturer before selecting boiler for installations having unusual piping and pick-up requirements, such as intermittent system operation, extensive piping, etc.
- (4) Heating Capacity and AFUE based on 13.0% CO<sub>2</sub> with -0.02" W.C. draft over fire and #1 smoke or less. Tested in accordance with U.S. Department of Energy test procedures.



2201 Dwyer Avenue, Utica, New York 13501  
 Phone: 315-797-1310 • Fax: 866-432-7329  
 E-mail: [info@ecrinternational.com](mailto:info@ecrinternational.com)  
 Web: [www.pennco boilers.com](http://www.pennco boilers.com)

**USA Contractor Assistance:**  
**800-325-5479**