

PENNCO 

Models
15B045FE
15B070FE
15B096FE
15B120FE
15B145FE
15B170FE
15B195FE
15B245FE
15B295FE

15B SERIES II

Cast Iron Gas Fired Boilers
For Forced Hot Water

INSTALLATION, OPERATION & MAINTENANCE MANUAL



C.S.A. Certified
For Natural Gas Or Propane



Tested For 100 psi
ASME
Working Pressure



Manufactured by:

ECR International, Inc.

2201 Dwyer Avenue,
Utica NY 13501

web site: www.ecrinternational.com



An ISO 9001-2008 Certified Company

P/N 240009024, Rev. A [03/2012]

TABLE OF CONTENTS

1 - Ratings & Data - Natural Gas & Propane Gas	4
2 - Dimensions	5
3 - Installation Procedure	6
4 - Ventilation & Combustion Air	7
5 - Connecting Supply & Return Piping	8
6 - Vent Installation	14
7 - Vent System Modification	14
8 - Vent Damper Installation & Instructions	15
9 - Connecting Gas Service	16
10 - Electrical Section	17
11 - Wiring Diagram	18
12 - Lighting Instructions	21
13 - Normal Sequence Of Operation	22
14 - General Instructions	22
15 - Checking Gas Input Rate To Boiler	24
Appendix A - Control Module	25
A.1 Installation Environment Considerations	25
A.2 Electrical Connections	25
A.3 Adjusting Settings	25
A.4 Display	25
A.5 Operation	26
A.6 Boiler High Limit Temperature Controller.....	27
A.8 Troubleshooting Error Codes	27
A.9 Intermittent Pilot Ignition System Verification.....	28

SAFETY MESSAGES

IMPORTANT: Read the following instructions **COMPLETELY** before installing!!

Safety Symbols & Warnings

The following defined symbols are used throughout this manual to notify the reader of potential hazards of varying risk levels.

DANGER

Indicates a hazardous situation which, if not avoided, **WILL** result in death or serious injury

WARNING

Indicates a hazardous situation which, if not avoided, could result in death or serious injury.

CAUTION

Indicates a hazardous situation which, if not avoided, could result in minor or moderate injury.

NOTICE

Used to address practices not related to personal injury.

**KEEP THIS MANUAL NEAR BOILER
RETAIN FOR FUTURE REFERENCE**

WARNING

Fire, explosion, asphyxiation and electrical shock hazard. Improper installation could result in death or serious injury. Read this manual and understand all requirements before beginning installation.

WARNING

Keep boiler area clear and free from combustible materials, gasoline and other flammable vapors and liquids.

DO NOT obstruct air openings to the boiler room. Modification, substitution or elimination of factory equipped, supplied or specified components may result in personal injury or loss of life.

TO THE OWNER - Installation and service of this boiler must be performed by a qualified installer.

TO THE INSTALLER - Leave all instructions with boiler for future reference.

When this product is installed in the Commonwealth of Massachusetts the installation must be performed by a Licensed Plumber or Licensed Gas Fitter.

1 - RATINGS & DATA - NATURAL GAS & PROPANE GAS



Table 1 - Ratings and Capacities

Model No.	Input Mbh ⁽¹⁾	Heating Capacity Mbh ⁽¹⁾	Net AHRI Rating Water Mbh ^{(2) **}	AFUE Elect. Ign.	No. Of Burners	Recommended Air Cushion Tank ⁽³⁾	Water Content (Gals.)
15B045	45	37	32	82.0%	1	15	2.4
15B070	70	57	50	82.0%	2	15	4.0
15B096	96	79	69	82.0%	2	30	4.0
15B120	120	98	85	82.0%	3	30	5.6
15B145	145	119	103	82.0%	3	30	5.6
15B170	170	140	122	82.0%	4	30	7.2
15B195	195	160	139	82.0%	4	30	7.2
15B245	245	201	174	82.0%	5	30	8.8
15B295	295	242	210	82.0%	6	60	10.4

EXPLANATORY NOTES

- All boilers are design certified for installation on noncombustible floor.
 - Recommended chimney height 20 feet. In special cases where conditions permit, chimney height may be reduced to 10 feet. Refer to the latest revision of NFGC part 11.
 - Electric service to be 120 Volts, 15 Amps, 60 Hz.
 - The MEA number for the this boiler is 19-79-E.
- (1) Input rating for sea level to 2,000 ft. (610m) above sea level.
United States, over 2000 ft (610m) above sea level. Reduce input rate 4% for every 1,000 ft (304m) above sea level.
 - (2) Net AHRI Water Ratings shown based on piping and pickup allowance of 1.15. Consult manufacturer before selecting boiler for installations having unusual piping and pickup requirements, such as intermittent system operation, extensive piping systems, etc.
 For forced hot water systems where boiler and all piping within area to be heated, boiler may be selected on basis of its heating capacity.
 - (3) Tank sized for non-ferrous baseboard or radiant panel systems. Increase size for cast iron baseboard and radiation.

STANDARD EQUIPMENT: Boiler Jacket, Cast Iron Boiler Battery, High Limit Control, Intermittent Electric Ignition Pilot System, Vent Damper Relay, Circulator With Return Piping To Boiler, Main Gas Burners, Gas Control (Includes Automatic Gas Valve, Gas Pressure Regulator, Intermittent Pilot, Safety Shutoff, Pilot Flow Adjustment, Pilot Filter), A.S.M.E. Relief Valve, Drain Valve, Spill Switch, Rollout Switch, Combination Gas Control, Automatic Vent Damper. Not Shown Are: Wiring Harness,, Non-linting Safety Pilot.

2 - DIMENSIONS

Dimensions

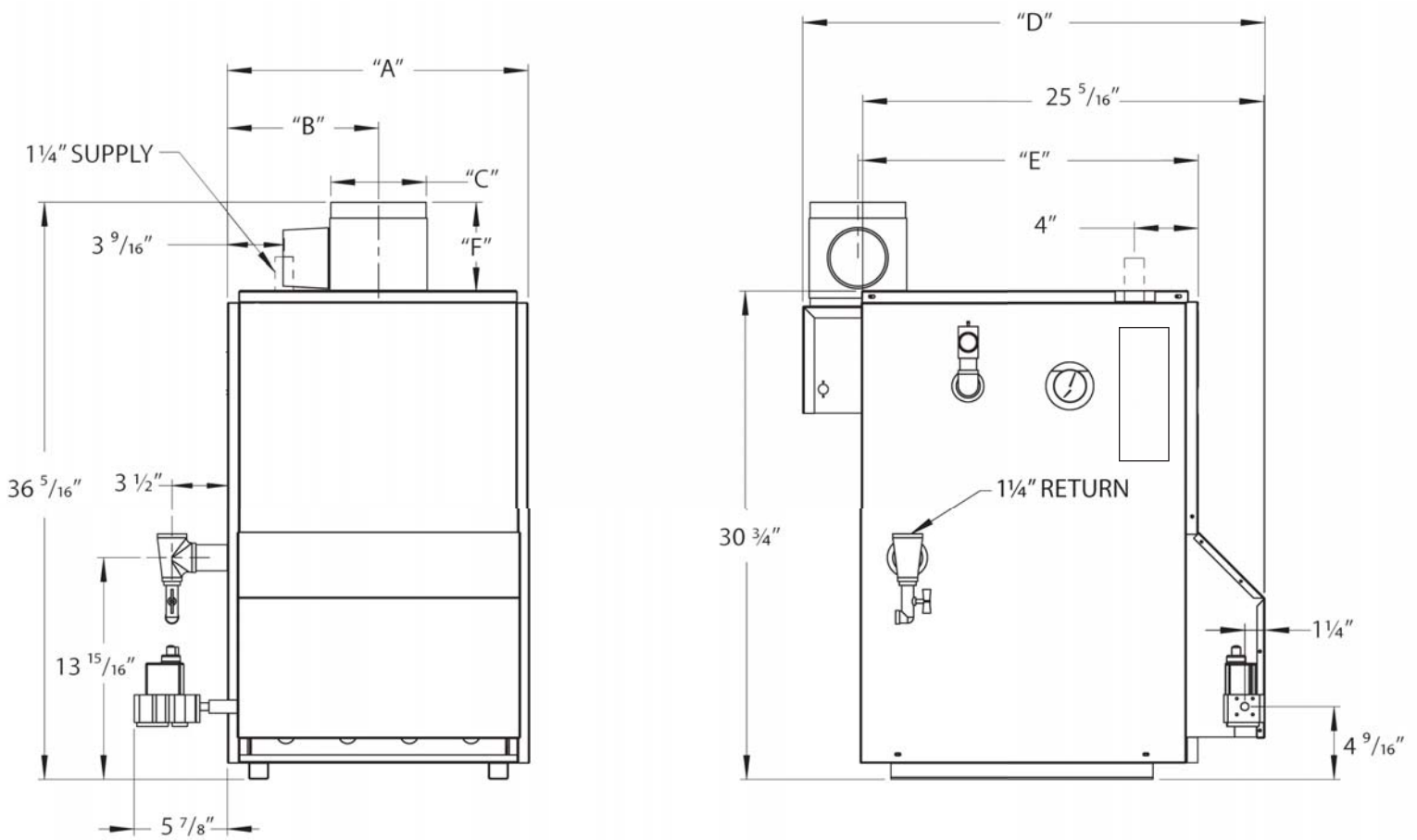

Table 2 - Dimensions

Model No.	Natural Gas Inlet*	Dimensions (Inches)						Pump Size Supply & Return Tappings
		A	B	C	D	E	F	
15B045	1/2"	11 1/4	5 5/8	4	27 1/8	20 7/16	4 15/16	1 1/4"
15B070	1/2"	15 1/8	7	5	28 1/8	20 15/16	4 15/16	1 1/4"
15B096	1/2"	15 1/8	7	5	28 1/8	20 15/16	4 15/16	1 1/4"
15B120	1/2"	19	9 1/2	6	29 1/8	21 7/16	5 7/16	1 1/4"
15B145	1/2"	19	9 1/2	6	29 1/8	21 7/16	5 7/16	1 1/4"
15B170	1/2"	22 7/8	11 3/16	7	30 1/8	21 15/16	5 15/16	1 1/4"
15B195	1/2"	22 7/8	11 3/16	7	30 1/8	21 15/16	5 15/16	1 1/4"
15B245	3/4"	26 3/4	13 6/16	8	31 1/8	22 7/16	6 15/16	1 1/4"
15B295	3/4"	30 5/8	15 5/16	9	32 1/8	22 15/16	8 15/16	1 1/4"

* Propane Gas Inlet (All Units) 1/2"

3 - INSTALLATION PROCEDURE

⚠ WARNING

Improper installation, adjustment, alteration, service or maintenance could result in death or serious injury.

1. Installation must conform to requirements of authority having jurisdiction or, in absence of such requirements, to the National Fuel Gas Code, ANSI Z223.1/NFPA 54.
2. Where required by authority having jurisdiction, installation must conform to the Standard for Controls and Safety Devices for Automatically fired Boilers, ANSI/ASME CSD-1.
3. Boiler series is classified as Category I. Vent installation shall be in accordance with "Venting of Equipment," of the National Fuel Gas Code, ANSI Z223.1/NFPA 54, or applicable provisions of local building codes.
4. Boiler has met safe lighting and other performance criteria with gas manifold and control assembly on boiler per latest revision of ANSI Z21.13/CGA 4.9.
5. Boiler shall be installed such that gas ignition system components are protected from water (dripping, spraying, rain, etc.) during appliance operation and service, (circulator replacement, condensate trap, control replacement, etc.).
6. Locate boiler on level, solid base as near chimney as possible and centrally located with respect to heat distribution system as practical.
7. Allow 24 inches (610mm) at front and right side for servicing and cleaning.
8. When installed in utility room, door should be wide enough to allow largest boiler part to enter, or to permit replacement of another appliance such as water heater.

⚠ WARNING

Fire hazard. Do not install boiler on combustible flooring or carpeting. Failure to follow these instructions could result in death or serious injury.

9. **FOR INSTALLATION ON NON-COMBUSTIBLE FLOORS ONLY** - For installation on combustible flooring special base must be used. (See Replacement Parts Section.) **Boiler can not be installed on carpeting.** Minimum clearances to combustible construction are:

TOP	18 IN. (457mm)
FRONT	ALCOVE *
FLUE CONNECTOR	6 IN. (152mm)
REAR.....	8 IN. (229mm)
CONTROL SIDE	9 IN. (76mm)
OTHER SIDE.....	3 IN. (76mm)
HOT WATER PIPING	2 IN. (51mm)

NOTE: Greater clearances for access should supersede fire protection clearances.

* Definition of Alcove is three sided space with no wall in front of boiler. ANSI standard for alcove is 18 inches from front of appliance to leading edge of side walls as shown below.

Minimum Clearances To Combustible Construction (As Seen From Above)

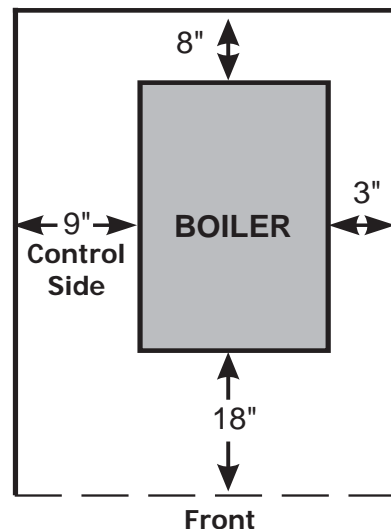

4 - VENTILATION & COMBUSTION AIR

Provide combustion air and ventilation air in accordance with the section "Air for Combustion and Ventilation," of the National Fuel Gas Code, ANSI Z223.1 / NFPA 54, or applicable provisions of local building codes.

Provide make-up air where exhaust fans, clothes dryers, and kitchen ventilation equipment interfere with proper operation.

National Fuel Gas Code recognizes several methods of obtaining adequate ventilation and combustion air. Requirements of the authority having jurisdiction may override these methods.

- **Engineered Installations.** Must be approved by authority having jurisdiction.
- **Mechanical Air Supply.** Provide minimum of 0.35 cfm per Mbh for all appliances located within space. Additional requirements where exhaust fans installed. Interlock each appliance to mechanical air supply system to prevent main burner operation when mechanical air supply system not operating.
- **All Indoor Air.** Calculate minimum volume for all appliances in space. Use a different method if minimum volume not available.

A. Standard Method. Cannot be used if known air infiltration rate is less than 0.40 air changes per hour. See Table 3 for space with boiler only. Use equation for multiple appliances.

$$\text{Volume} \geq 50 \text{ ft}^3 \times \text{Total Input [Mbh]}$$

B. Known Air Infiltration Rate. See Table 1 for space with boiler only. Use equation for multiple appliances. Do not use an air infiltration rate (ACH) greater than 0.60.

$$\text{Volume} \geq 21 \text{ ft}^3/\text{ACH} \times \text{Total Input [Mbh]}$$

- C. **Refer to National Fuel Gas Code** for opening requirements between connected indoor spaces.
- **All Outdoor Air.** Provide permanent opening(s) communicating directly or by ducts with outdoors.
 - A. **Two Permanent Opening Method.** Provide opening commencing within 12 inches of top and second opening commencing within 12 inches of bottom of enclosure.
 - Direct communication with outdoors or communicating through vertical ducts. Provide minimum free area of 1 in² per 4 Mbh of total input rating of all appliances in enclosure.
 - Communicating through horizontal ducts. Provide minimum free area of 1 in² per 2 Mbh of total input rating of all appliances in enclosure.
 - B. **One Permanent Opening Method.** Provide opening commencing within 12 inches of top of enclosure. Provide minimum clearance of 1 inch on sides/back and 6 inches on front of boiler (does not supersede clearance to combustible materials).
 - C. **Refer to National Fuel Gas Code** for additional requirements for louvers, grilles, screens and air ducts.
- **Combination Indoor and Outdoor Air.** Refer to National Fuel Gas Code for application information.

Table 3 - Minimum Room Volume, Indoor Air Only*

Input Mbh	Standard Method	Known Air Infiltration Rate Method (Air Changes Per Hour)					
		0.1	0.2	0.3	0.4	0.5	0.6
45	2250	9450	4725	3150	2363	1890	1575
70	3500	14700	7350	4900	3675	2940	2450
96	4800	20160	10080	6720	5040	4032	3360
120	6000	25200	12600	8400	6300	5040	4200
145	7250	30450	15225	10150	7613	6090	5075
175	8750	36750	18375	12250	9188	7350	6125
195	9750	40950	20475	13650	10238	8190	6825
245	12250	51450	25725	17150	12863	10290	8575
295	14750	61950	30975	20650	15488	12390	10325

* Table values based on boiler only. Add volume for any additional appliances.



WARNING

Burn or Scald Hazard. Discharge line shall be installed to relief valve outlet connection to avoid burns, scalding, or water damage due to discharge of steam and/or hot water during operation.

Discharge line shall:

- connect to relief valve outlet and piped down to safe point of disposal. Check local codes for maximum distance from floor or allowable safe point of discharge.
- be of pipe size equal to or greater than that of the relief valve outlet over the entire length of discharge line;
- have no intervening shutoff valve between safety relief valve and discharge to atmosphere (do not plug or place any obstruction in discharge line).
- terminate freely to atmosphere where any discharge will be clearly visible and at no risk of freezing;
- allow complete drainage of the valve and the discharge line;
- be independently supported and securely anchored to avoid applied stress on the relief valve;
- be as short and straight as possible;
- terminate with plain end (not threaded);
- be constructed of material suitable for exposure to temperatures of 375° F (191°C); or greater.

Refer to local codes and appropriate ASME Boiler and Pressure Vessel Code for additional installation requirements.

Figure 1 - Safety Relief Valve

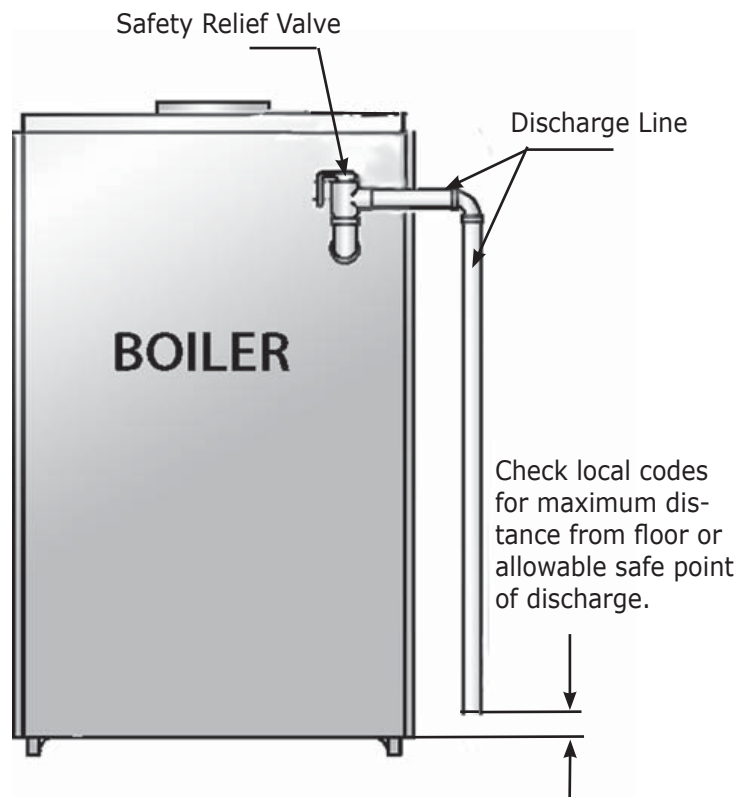

5 - CONNECTING SUPPLY & RETURN PIPING

Hydronic Piping - General

- Install piping in accordance with authority having jurisdiction.
- Support system piping and safety relief valve discharge piping.

Special Conditions

- System piping exposed to freezing conditions: Use inhibited propylene glycol solutions certified by fluid manufacturer for use with closed water heating system. Do not use automotive or ethylene glycol.
- Boiler installed above radiation level (or as required by authority having jurisdiction). Install low water cutoff.
- Boiler used in connection with refrigeration system. Install piping in parallel with boiler, with appropriate valves to prevent chilled medium from entering boiler. See Figure 2, Page 10.
- System piping connected to heating coils located in air handling unit exposed to refrigerated air circulation. Install flow control valves or other automatic means to prevent gravity circulation of boiler water during cooling cycle.

Safety Relief Valve

WARNING

Burn and scald hazard. Safety relief valve could discharge steam or hot water during operation. Install discharge piping per these instructions.

NOTICE

Boiler rated at 100 psig maximum allowable working pressure. Boiler provided with 30 psig safety relief valve. Field source safety relief valve for system pressures greater than 30 psig. Temperature-pressure gauge provided with boiler is satisfactory for 30-50 psig operation. Replace temperature-pressure gauge for system pressure over 50 psig. Scale on dial must be graduated to not less than 1½ nor more than 3½ time safety relief valve pressure settings.

- Do not install shutoff valve between boiler and safety relief valve.
- Systems with automatic fill valves require back flow prevention device.
- Install discharge piping from safety relief valve. See Warning, Page 8.
- When boiler is connected to heating system utilizing multiple zoned circulators, each circulator must be supplied with flow control valve to prevent gravity circulation.
- Hot water boilers and system must be filled with water and maintained to minimum pressure of 12 psi.
- Bypass piping is an option which gives ability to adjust the supply boiler water temperature to fit the system or condition of installation. This method of piping, however, is not typically required for baseboard heating systems. Typical installations where bypass piping is used are as follows:
 - A. This method is used to protect boilers from condensation forming due to low temperature return water. Generally noticed in large converted gravity systems or other large water volume systems. Figures 3 & 4, Page 11.
 - B. These methods are used to protect systems using radiant panels and the material they are encased in from high temperature supply water from the boiler and protect boiler from condensation.

NOTE#1: When using bypass piping, adjust valves V1 & V2 until desired system temperature is obtained.

NOTE#2: Bypass loop must be same size piping as the supply and return piping.

- Installation using circulators and zone valves are shown in Figures 3-8 . For further piping information refer to AHRI Installation and Piping Guide.
- For zone controls and indirect hot water, refer to appropriate manufacturer instructions.

5 - CONNECTING SUPPLY AND RETURN PIPING

NOTICE

Circulators in following illustrations are mounted on system supply side, mounting on system return side is also acceptable practice.

**Figure 2 - Circulators Mounted on Supply System, Boiler Used In Configuration to Chiller System.
See Special Conditions, Page 9**

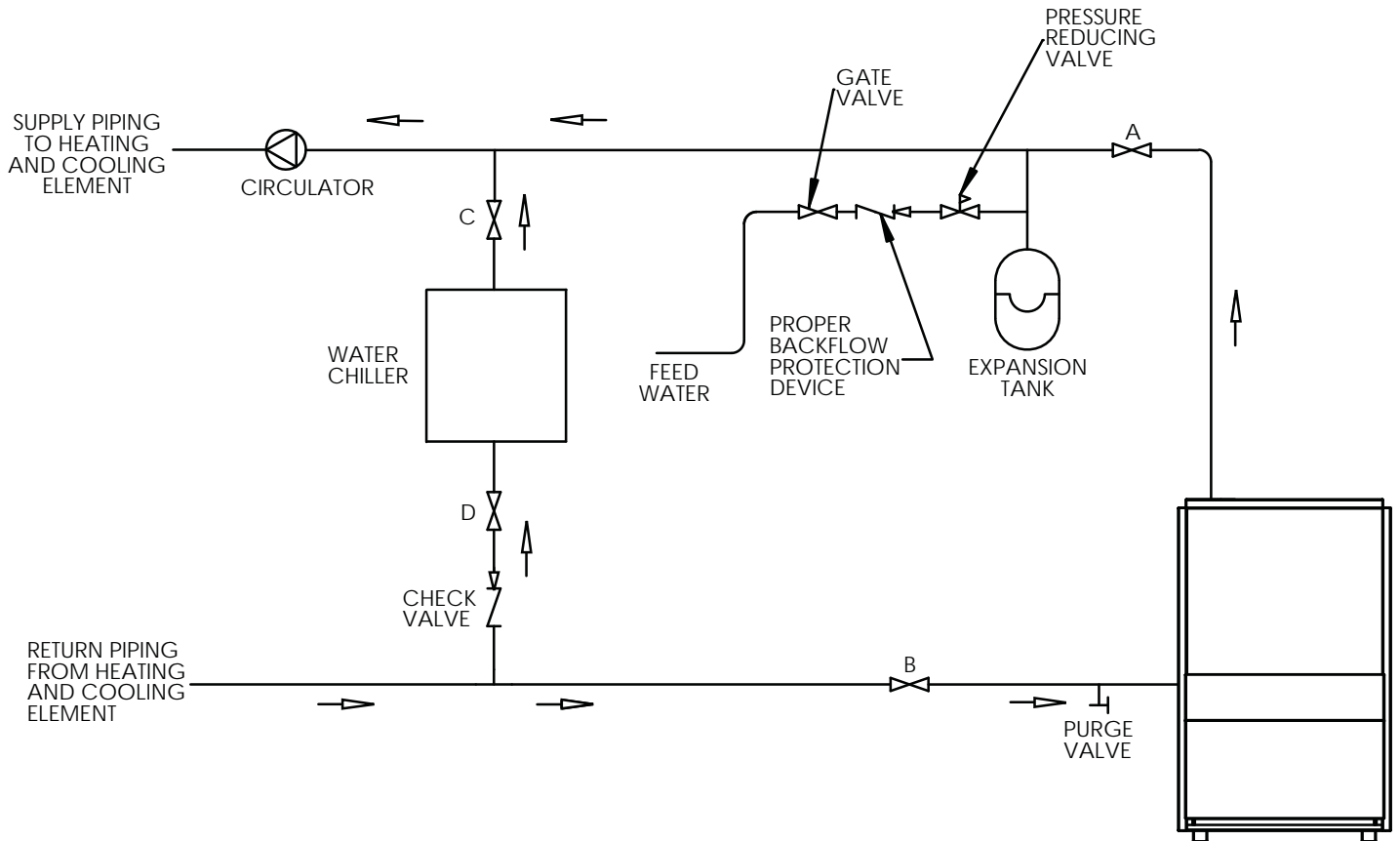

5 - CONNECTING SUPPLY AND RETURN PIPING

Figure 3 - Bypass Piping -Automatic Mixing Valve, See Bypass Piping Options, Page 9

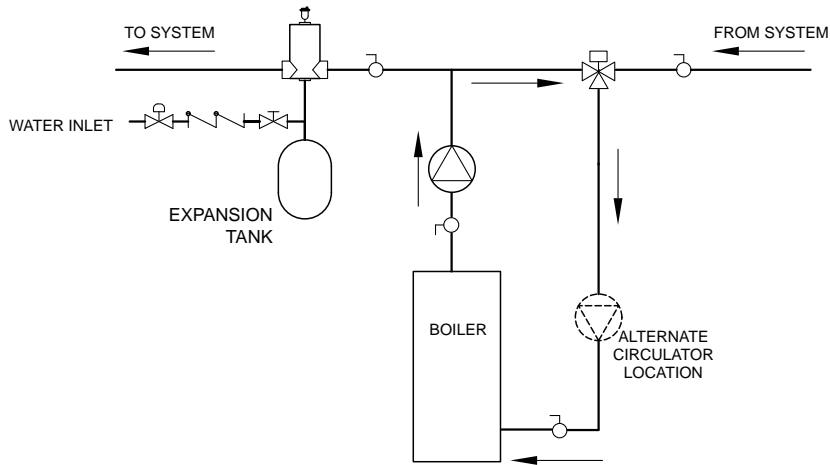

Note: Bypass connection not showing primary/secondary piping

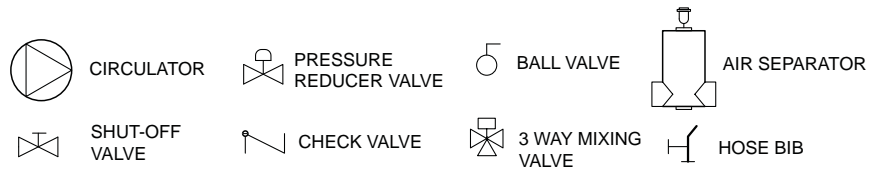
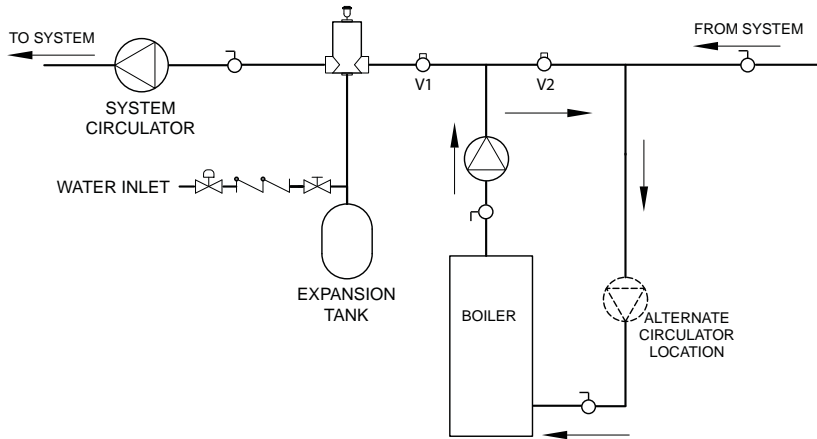

Figure 4 - Bypass Piping - Fixed Low Temp Only, See Bypass Piping Options, Page 9



Note: Bypass connection not showing primary/secondary piping



5 - CONNECTING SUPPLY AND RETURN PIPING

Figure 5 - Single Zone System With DHW Priority

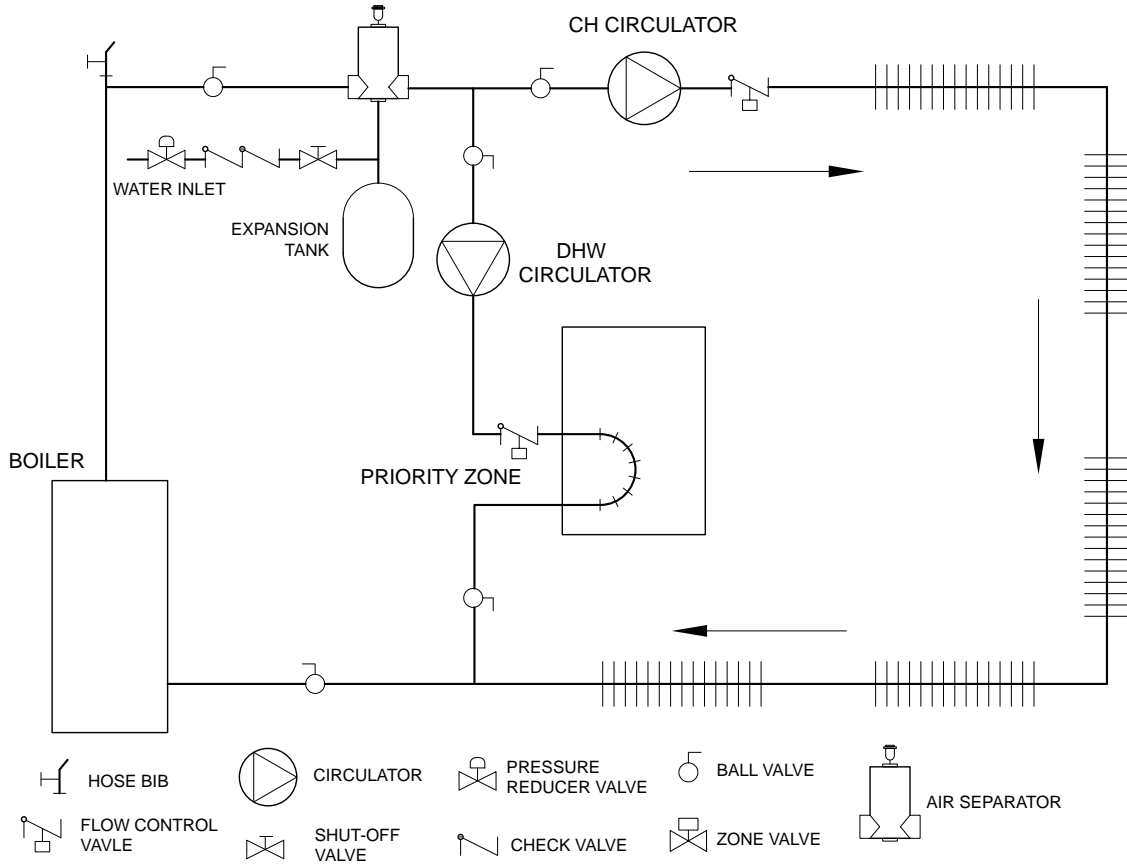
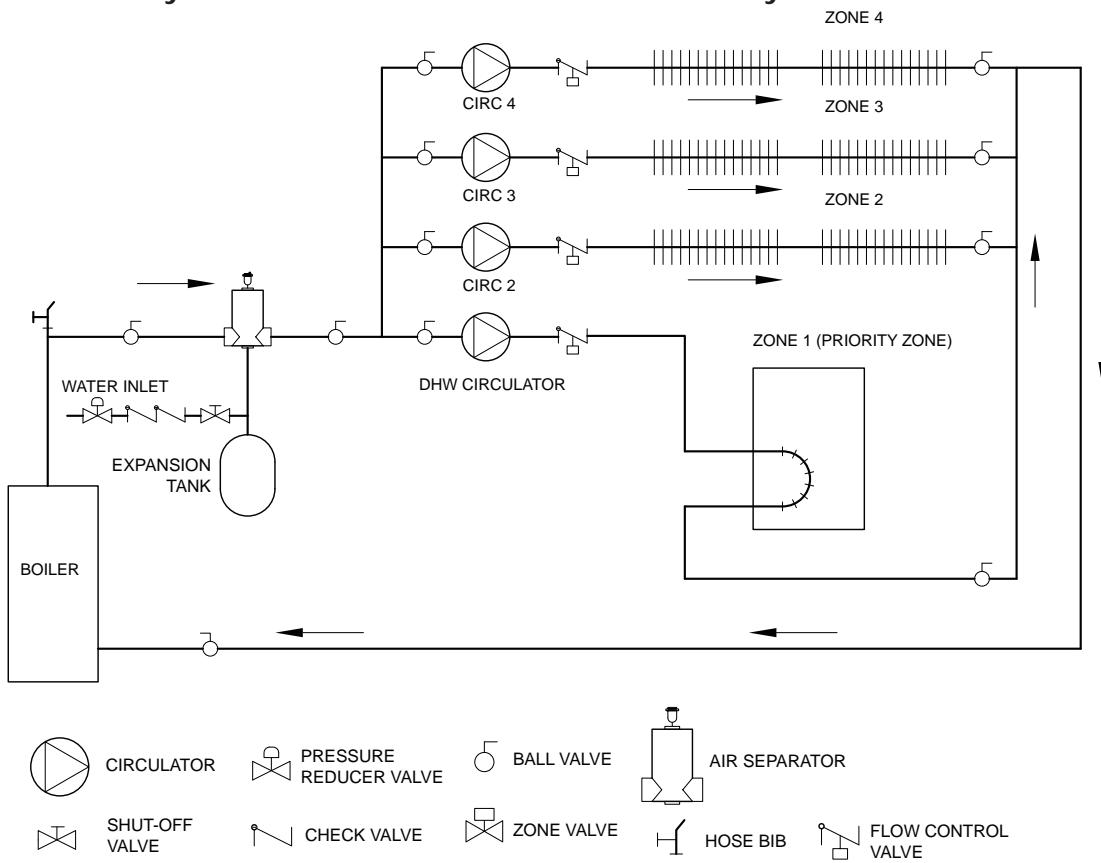

Figure 6 - Multi-Zone System with Circulators and DHW Priority



5 - CONNECTING SUPPLY AND RETURN PIPING

Figure 7 - Multi-zone System With Zone Valves And DHW Priority (With Circulator)

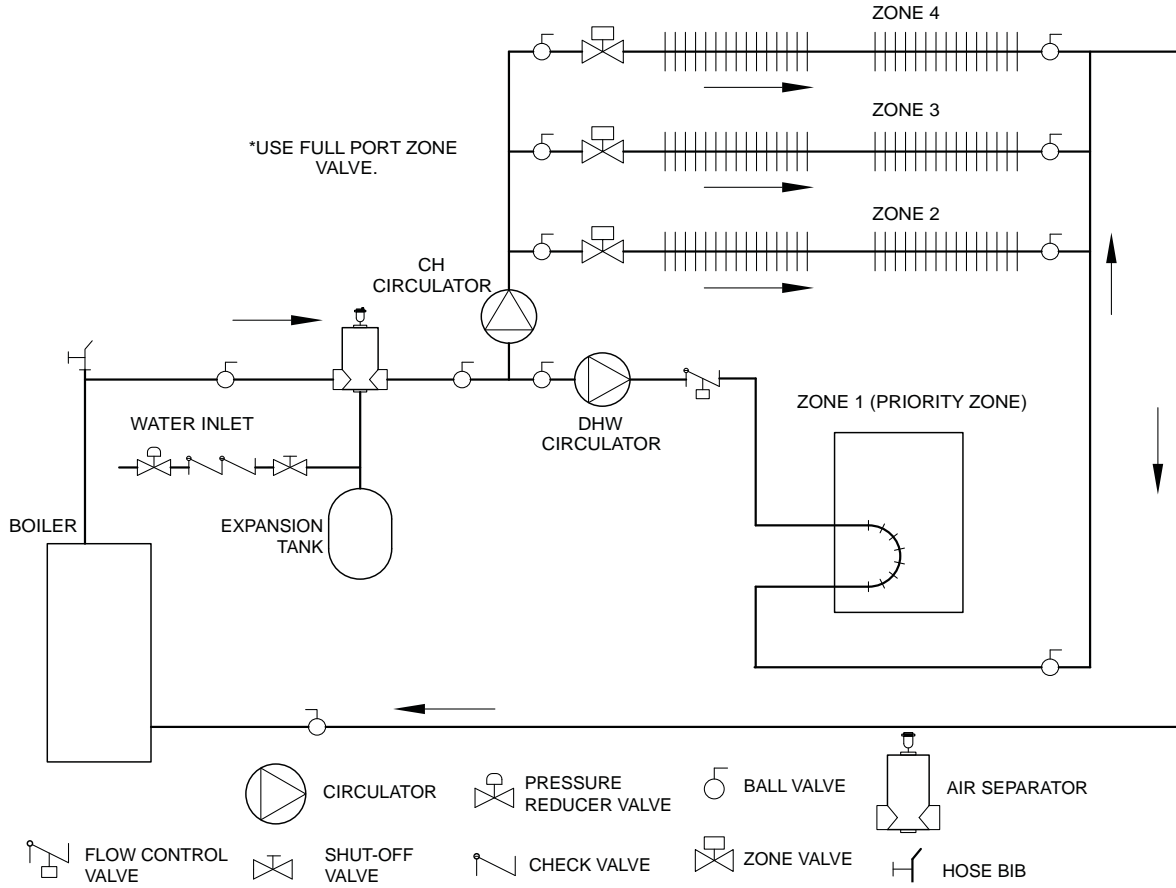
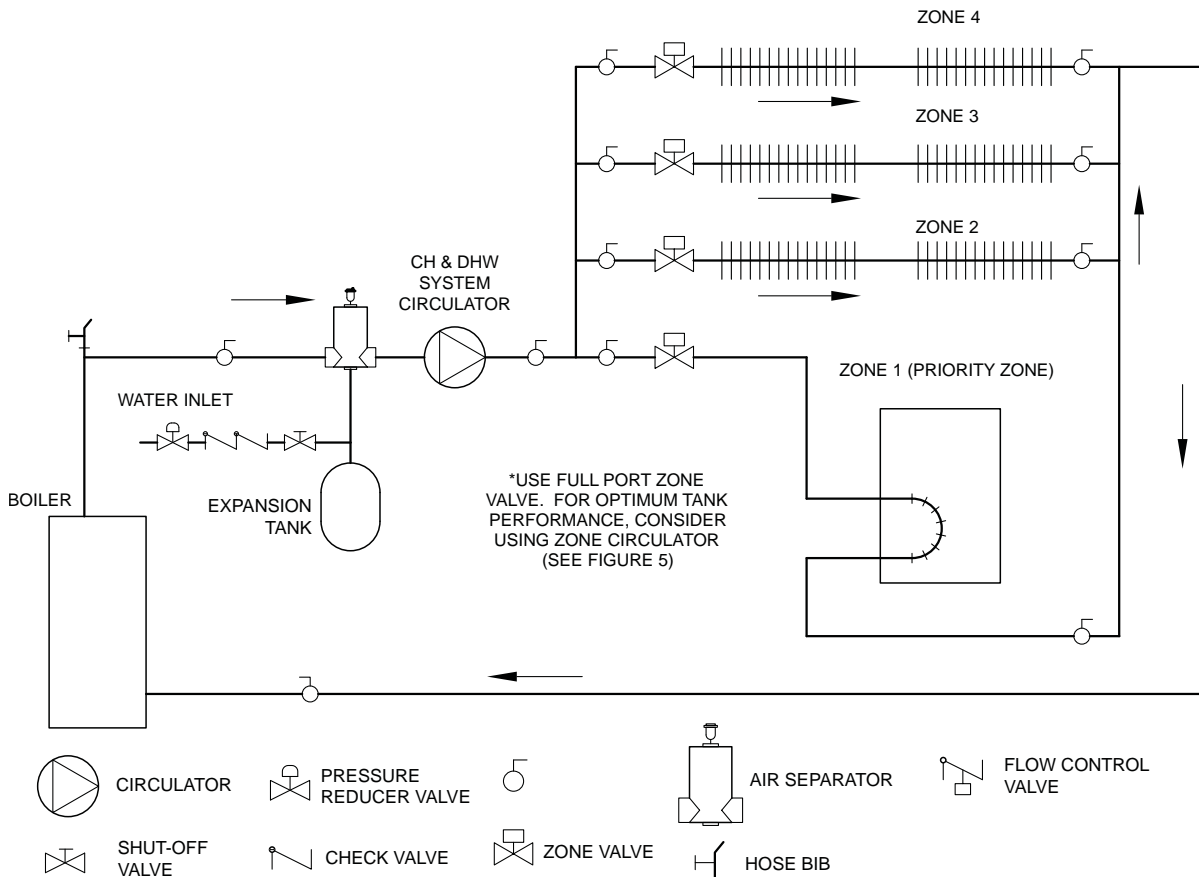

Figure 8 - Multi-zone System With Zone Valves And DHW Priority (With Zone Valve)



6 - VENT INSTALLATION

WARNING

Boiler and venting installations shall be performed by a qualified expert and in accordance with the appropriate manual. Installing or venting boiler or other gas appliance with improper methods or materials may result in serious injury or death due to fire or to asphyxiation from poisonous gases such as carbon monoxide which is odorless and invisible.

WARNING

Do not connect boiler to any portion of mechanical draft system operating under positive pressure.

1. Vent pipe must slope upward from boiler not less than $\frac{1}{4}$ inch per 1 foot to the vent terminal.
2. Horizontal portions of venting system shall be supported rigidly every 5 feet and at elbows. No portion of vent pipe should have any dips or sags.
3. This boiler series is classified as Category I. Vent installation shall be in accordance with "Venting of Equipment," of the National Fuel Gas Code, ANSI Z223.1/NFPA 54, or applicable provisions of the local building codes.
4. Vent connectors serving appliances vented by natural draft shall not be connected into any portion of mechanical draft systems operating under positive pressure.
5. Connect flue pipe from draft hood to chimney. Bolt or screw joints together to avoid sags. Flue pipe should not extend beyond inside wall of chimney. Do not install manual damper in flue pipe or reduce size of flue outlet except as provided by the latest revision of ANSI Z223.1. Protect combustible ceiling and walls near flue pipe with fireproof insulation. Where two or more appliances vent into a common flue, the area of the common flue must be at least equal to the area of the largest flue plus 50 percent of the area of each additional flue.

7 - VENT SYSTEM MODIFICATION

When existing boiler is removed from a common venting system, the system is likely to be too large for the proper venting of the appliances still connected to it.

Removal Of Boiler From Venting System

At the time of removal of an existing boiler, the following steps shall be followed with each appliance remaining connected to the common venting system placed in operation, while the other appliances remaining connected to the common venting system are not in operation.

1. Seal any unused opening in the common venting system.
2. Visually inspect the venting system for proper size and horizontal pitch and determine there is no blockage or restriction, leakage, corrosion and other deficiencies which could cause an unsafe condition.
3. Insofar as is practical, close all building doors and windows and all doors between the space in which the appliances remaining connected to the common venting system are located and other spaces of the building. Turn on clothes dryers and any other appliance not connected to the common venting system. Turn on any exhaust fans, such as range hoods and bathroom exhausts, so they operate at maximum speed. Do not operate a summer exhaust fan. Close fireplace dampers.
4. Place in operation the appliance being inspected. Follow the lighting instructions. Adjust thermostat so appliance will operate continuously.
5. Test for spillage at the draft hood relief opening after 5 minutes of main burner operation. Use the flame of a match or candle, or smoke from a cigarette, cigar or pipe.
6. After it has been determined that each appliance remaining connected to a common venting system properly vents when tested as outlined above, return doors, windows, exhaust fans, fireplace dampers and any other gas burning appliances to their previous condition of use.
7. Any improper operation of the common venting system should be corrected so the installation conforms with the National Fuel Gas Code, ANSI Z223.1/NFPA 54. When re-sizing any portion of the common venting system, the common venting system should be re-sized to approach the minimum size as determined using the appropriate tables in Chapter 13 of the National Fuel Gas Code, ANSI Z223.1/NFPA 54.

8 - VENT DAMPER INSTALLATION & INSTRUCTIONS

Figure 9 - Damper Installation

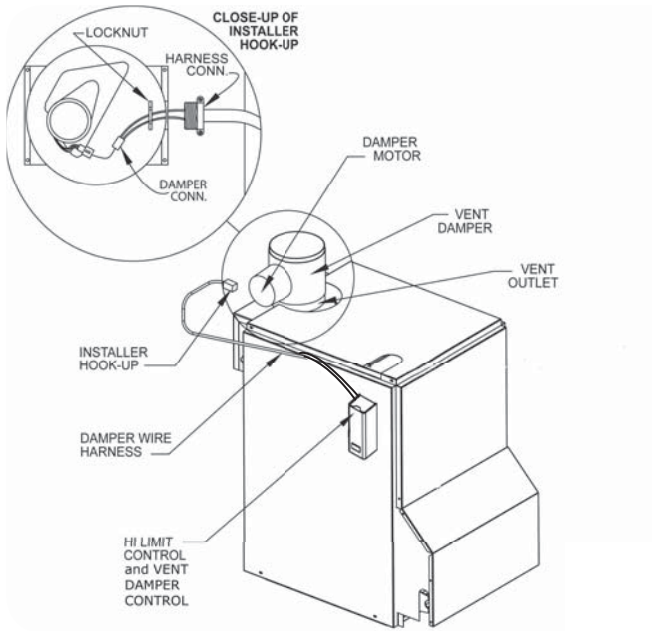

NOTE: Refer to *Figure 9* for steps 1-6.

1. Place Vent Damper on or as close to vent outlet of boiler as possible. Do not modify draft hood or vent damper during installation.
2. Remove Vent Damper Motor cover.
3. Feed damper wire harness connector through bracket hole on damper motor frame.
4. Tighten locknut onto Damper wire harness connector.
5. Plug Damper connector into socket on damper motor frame.
6. Replace damper motor cover and wire damper as.

Figure 10 - Damper Location

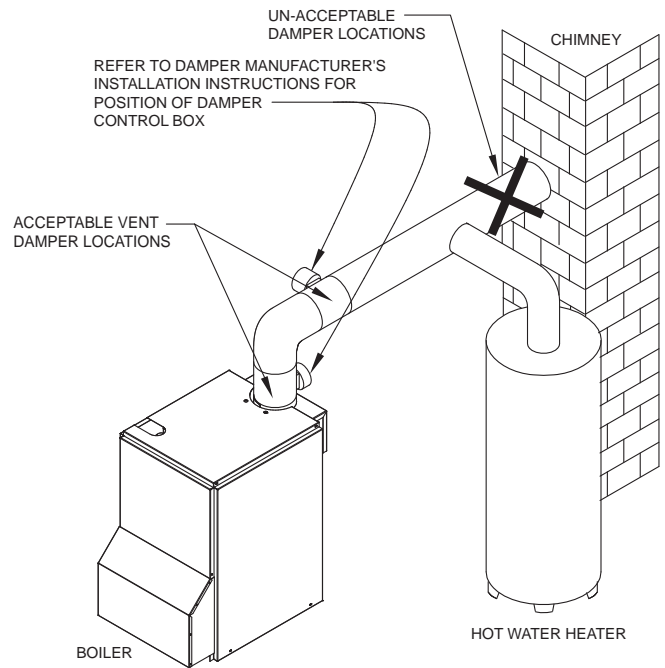

1. Verify only boiler is serviced by vent damper. See Figure 10 .
2. Clearance of not less than 6 inches between vent damper and combustible material must be maintained. Additional clearance should be allowed for service of Vent Damper.
3. Vent damper must be in open position when appliance main burners are operating.
4. Vent damper position indicator must be in visible location following installation.
5. Thermostat's heat anticipator must be adjusted to match total current draw of all controls associated with boiler during heating cycle.

9 - CONNECTING GAS SERVICE

⚠ CAUTION

WHAT TO DO IF YOU SMELL GAS

- Do not try to light any appliance.
- Do not touch any electrical switch; do not use any phone in your building.
- Immediately call your gas supplier from a neighbor's phone. Follow gas supplier's instructions.
- If you cannot reach your gas supplier, call the fire department.

General

- Use piping materials and joining methods acceptable to authority having jurisdiction. In absence of such requirements of National Fuel gas Code, ANSI Z223.1/ NFPA 54
- Size and install gas piping system to provide sufficient gas supply to meet maximum input at not less than minimum supply pressure. See Table 5.
- Support piping with hooks straps, bands, brackets, hangers, or building structure components to prevent or dampen excessive vibrations and prevent strain on gas connection. Boiler will not support piping weight.
- Use thread (joint) compound (pipe dope) suitable for liquefied petroleum gas.
- Install field sourced manual main shutoff valve, ground joint union, and sediment trap upstream of gas valve. See Figure 11.

Figure 11 - Drip Leg

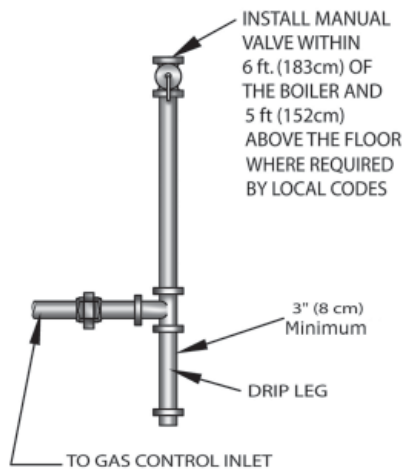

Maximum Capacity Of Pipe In Cubic Feet Of Gas/Hour
(Gas Pressure = 0.5 psig or less, Pressure Drop = 5 in. w/c)

Table 4 - Gas Piping

Length of Pipe (Feet)	Nominal Iron Pipe Size			
	1/2"	3/4"	1"	1 1/4"
10	175	360	680	1400
20	120	250	465	950
30	97	200	375	770
40	82	170	320	660
60	66	138	260	530
80	57	118	220	460
100	50	103	195	400

For additional information refer to the National Fuel Gas Code Handbook.

Table 5 - Gas Pressure		
	Natural Gas	Propane
Min. Supply Pressure	5" w.c.	11" w.c.
Max. Supply Pressure	13.5" w.c.	13.5" w.c.
Manifold Pressure	3.5" w.c.	10.5" w.c.

⚠ DANGER

Fire Hazard. Do not use matches, candles, open flames, or other methods providing ignition source. Failure to comply will result in death or serious injury.

Leak Check Gas Piping

Pressure test boiler and gas connection before placing boiler in operation.

- Pressure test over 1/2 psig (3.5 kPa). Disconnect boiler and its individual gas shutoff valve from gas supply system.
- Pressure test at 1/2 psig (3.5 kPa) or less. Isolate boiler from gas supply system by closing manual gas shutoff valve.
- Locate leakage using gas detector, noncorrosive detection fluid, or other leak detection method acceptable to authority having jurisdiction. Do not use matches, candles, open flames, or other methods providing ignition source.
- Correct leaks immediately and retest.

WARNING

Electrical shock hazard. Turn OFF electrical power supply at service panel before making electrical connections. Failure to do so could result in death or serious injury.

Electrical Wiring

See wiring diagrams on the following two pages for details.

Electrically bond boiler to ground in accordance with requirements of authority having jurisdiction. Refer to National Electrical Code, ANSI/NFPA 70.

Thermostat Installation

1. Install thermostat on inside wall about four feet above floor.
2. NEVER install thermostat on outside wall.
3. Do not install a thermostat where it will be affected by drafts, hot or cold pipes, sunlight, lighting fixtures, televisions, a fireplace, or a chimney.
4. Check thermostat operation by raising and lowering thermostat setting as required to start and stop burners.
5. Instructions for final adjustment of thermostat are packaged with thermostat (adjusting heating anticipator, calibration, etc.)

11 - WIRING DIAGRAM

Figure 12 - Integrated High Limit & Electronic Ignition Control (240008781)

⚠ WARNING
 Modification, substitution or elimination of factory equipped, supplied or specified components may result in personal injury or loss of life.

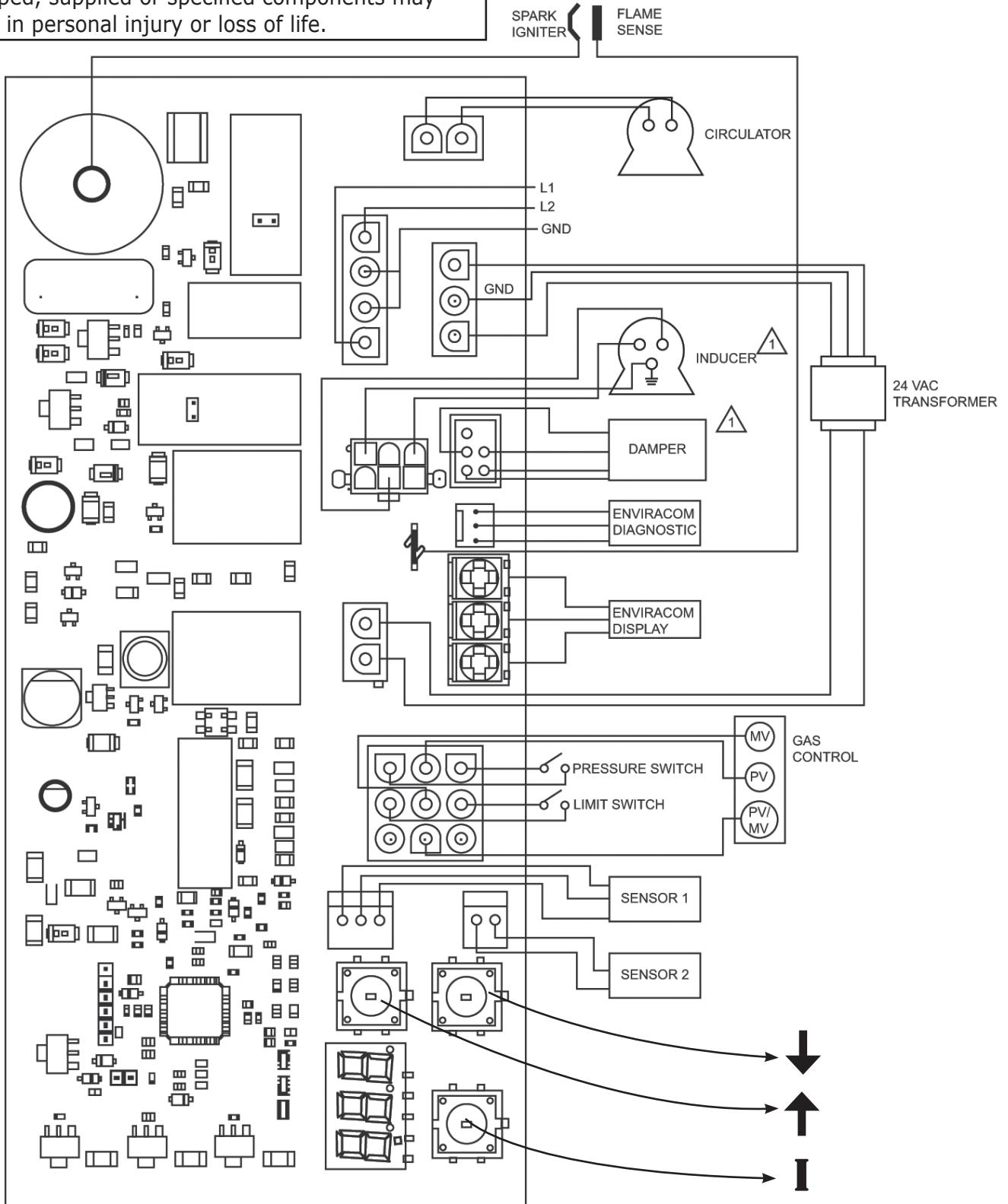

△ 1 OPTIONAL DEPENDING ON CONFIGURATION

Inducer is not an option.

11 - WIRING DIAGRAM

Figure 13 - Integrated High Limit & Electronic Ignition Control (240008781)

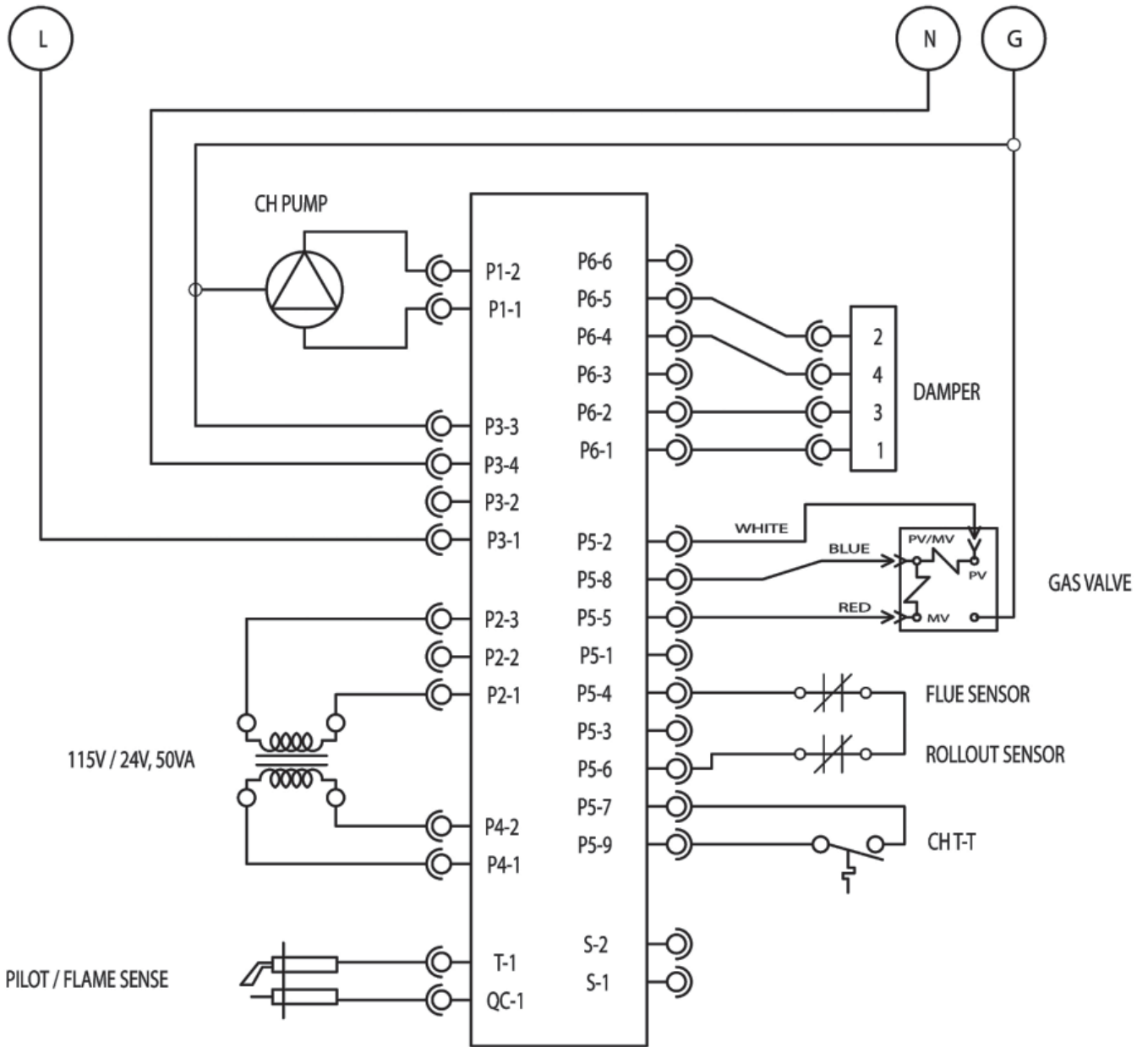

11 - WIRING DIAGRAM

Figure 14 - - Integrated High Limit & Electronic Ignition Control (240008781)

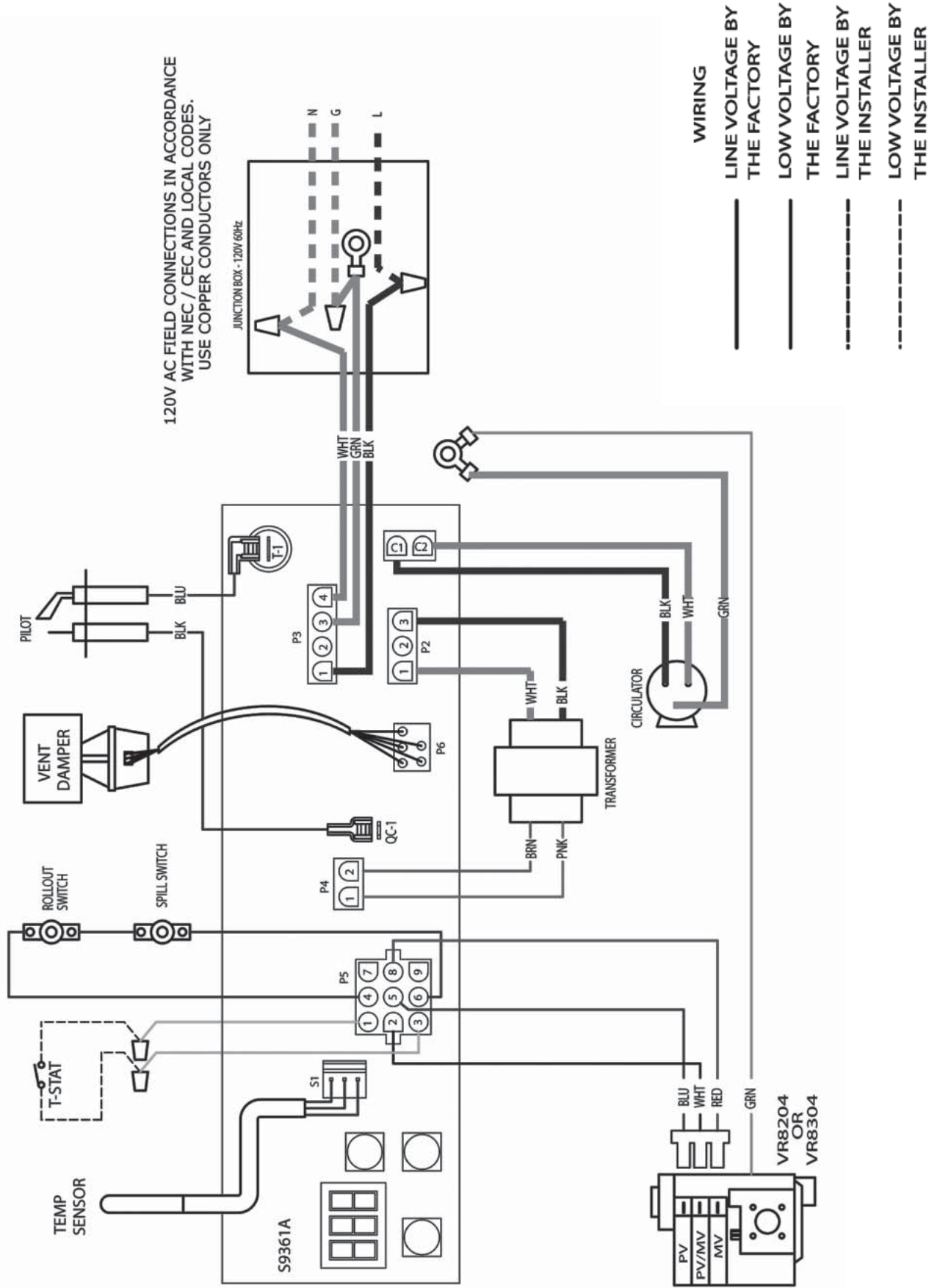

⚠ WARNING

If you do not follow these instructions exactly, a fire or explosion may result causing property damage, personal injury or loss of life.

- This appliance is equipped with an ignition device which automatically lights burner. **Do NOT try to light this burner by hand.**
- Before operating smell all around appliance area for gas. Be sure to smell next to floor because some gas is heavier than air and will settle to the floor.
- **Use only your hand to turn the gas shutoff valve.** Never use tools. If valve will not turn by hand, do not try to repair it, call a qualified service technician. Force or attempted repair may result in fire or explosion.
- **Do not use this appliance if any part has been under water.** Immediately call a qualified service technician to inspect appliance and to replace any part of control system and any gas control which has been under water.

NOTICE

Before lighting pilot burner, verify hot water boiler and system are full of water to minimum pressure of 12 psi in the system, also verify system is vented of air. Set operating control of thermostat to "below" normal setting. Refer to following appropriate lighting instruction.

LIGHTING PROCEDURE FOR BOILER WITH INTERMITTENT PILOT SYSTEM

- A. This appliance is equipped with an ignition device which automatically lights the pilot. Do not try to light the appliance by hand.

⚠ CAUTION

WHAT TO DO IF YOU SMELL GAS

- Do not try to light any appliance.
- Do not touch any electrical switches; do not use any phone in your building.
- Immediately call your gas supplier from a neighbor's phone. Follow the gas supplier's instructions.
- If you cannot reach your gas supplier, call the fire department.

OPERATING INSTRUCTIONS FOR INTERMITTENT PILOT SYSTEM

1. STOP! Read the safety information to the left.
2. Set the thermostat to lowest setting.
3. Turn off all electric power to the appliance.
4. This appliance is equipped with an ignition device which automatically lights the pilot. Do not try to light pilot by hand. See Figure 12.

Figure 15 - Intermittent Pilot

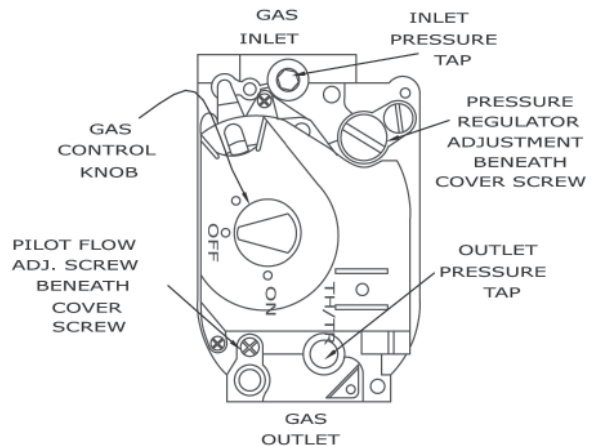

5. Turn gas control knob clockwise to "OFF."
6. Wait (5) minutes to clear out any gas. If you then smell gas, STOP! Follow "What To Do If You Smell Gas" in the safety information to the left. If you don't smell gas, go on to the next step.
7. Turn gas control knob counterclockwise to "ON."
8. Turn on all electric power to the appliance.
9. Set thermostat to desired setting.
10. If the appliance will not operate, follow the instructions "To Turn Off Gas To Appliance" , and call qualified service technician or your gas supplier.

TO TURN OFF GAS TO THE APPLIANCE

1. Set the thermostat to lowest setting.
2. Turn off all electric power to the appliance if service is to be performed.
3. Push in gas control knob slightly and turn clockwise to "OFF." DO NOT FORCE.
4. Call qualified service technician.

13 - NORMAL SEQUENCE OF OPERATION

Thermostat actuates on call for heat, completing circuit to control. Completed circuit to control will first activate circulator. Control will first monitor water temperature with circulator running to determine if thermostat can be satisfied without firing burner; if not it will activate damper which closes end switch inside damper. Action completes circuit to ignition system and ignition takes place.

In event boiler water temperature exceeds high limit setting on boiler mounted high limit control, power is interrupted between control system and ignition system. Power remains off until boiler water temperature drops below high limit setting. Circulator continues to operate under this condition until thermostat is satisfied.

In event flow of combustion products through boiler venting system becomes blocked, blocked vent safety switch shuts main burner gas off. Similarly, if boiler flue-way becomes blocked, flame rollout safety switch shuts main burner gas off. See Figure 16. If either of these conditions occur, **do not attempt to place boiler back into operation. Contact certified service agency.**

Figure 16 - Blocked Vent Safety Switch, Roll-out Safety Switch

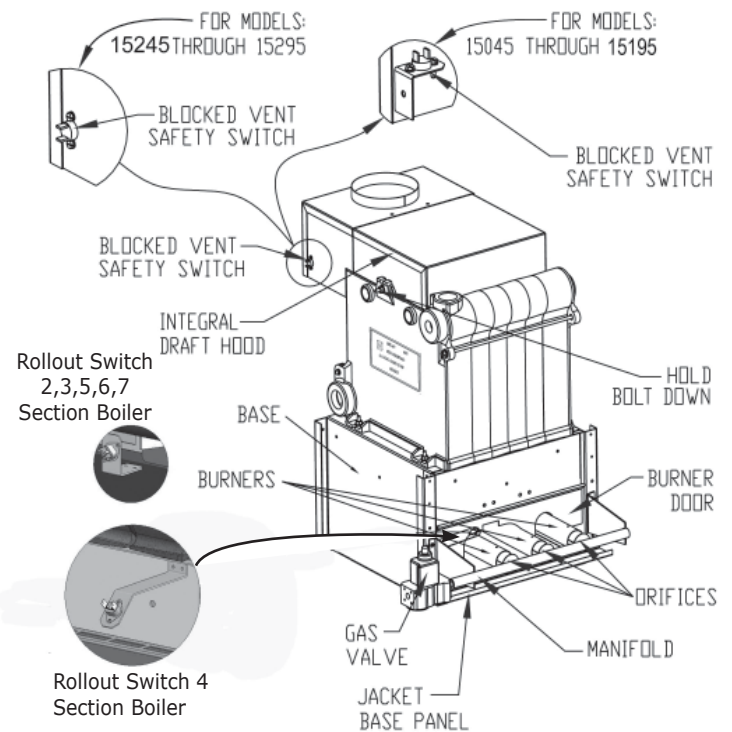

14 - GENERAL INSTRUCTIONS

Before seasonal start-up, have certified service agency check boiler for soot and scale in flues, clean burners and check gas input rate to maintain high operating efficiency.

! WARNING

Label all wires prior to disconnection when servicing controls. Wiring errors could cause improper and dangerous operation.

Verify proper operation after service.

Service agency will verify system is filled with water to minimum pressure and open air vents, if used, to expel any air accumulated in the system. Check piping system and, if leaks are found, have them repaired immediately.

Check and maintain circulators. Refer to circulator manufacturer's instructions.

Inspect venting system at the start of each heating season. Check vent pipe from boiler to chimney for signs of deterioration by rust or sagging joints. Repair if necessary. Remove vent pipe at base of chimney or flue and using mirror, check vent for obstruction and verify vent is in good working order.

Inspect boiler flue gas passageways by a light and mirror. Remove burner door. Place trouble lamp in flue collector through draft relief opening. With mirror positioned above burners, flue gas passageways can be checked for soot or scale. See Figure 16.

Follow the following procedure to clean flue gas passageways:

1. Remove burners from combustion chamber by raising burners up from manifold orifices and pulling toward front of boiler. See Figure 18, Page 23.
2. Disconnect vent pipe from draft hood.
3. Remove top jacket panel.
4. Remove combination flue collector and draft hood from boiler castings by loosening nuts on hold down bolts located on each side of collector. See Figure 16.
5. Place sheet of heavy paper or similar material over bottom of base and brush down flue passageways. Soot and scale will collect on paper and is easily removed with the paper.
6. With paper still in place in base, clean top of boiler castings of boiler putty or silicone used to seal between castings and flue collector. Verify chips are not lodged in flue passageways.

When cleaning process is complete, restore boiler components to their original position. Use IS-808 GE silicone to seal around flue collector and boiler castings.

14 - GENERAL INSTRUCTIONS



- Make visual inspection of main burner and pilot flames at start of heating season and again in mid-season. Main burner flame should have well defined inner blue mantel with lighter blue outer mantel. Check burner throats and burner orifices for lint or dust obstruction. See Figure 17.
- Pilot flame should envelop $\frac{3}{8}$ to $\frac{1}{2}$ inch of tip of ignition/sensing electrode. See Figure 19.
- To adjust pilot flame, remove pilot adjustment cover screw and turn inner adjustment screw counterclockwise  to increase or clockwise  to decrease pilot flame. Be sure to replace cover screw after adjustment to prevent possible gas leakage. See Figure 12, Page 18.
- Check burners and pilot for signs of corrosion, rust or scale buildup. Area around boiler must be kept clear and free of combustible materials, gasoline and other flammable vapors and liquids.
- Free flow of combustion and ventilating air to boiler and boiler room must not be restricted or blocked.
- Inspect field sourced low water cutoffs annually, or as recommended by low water cutoff manufacturer. Flush float type low water cutoffs per manufacturer's instructions.
- Employ a qualified service agency to make annual inspection of boiler and heating system. They are experienced in making the inspections outlined above, and, in event repairs or corrections are necessary, trained technicians make the proper changes for safe operation of the boiler.

Figure 17 - Burner Flame

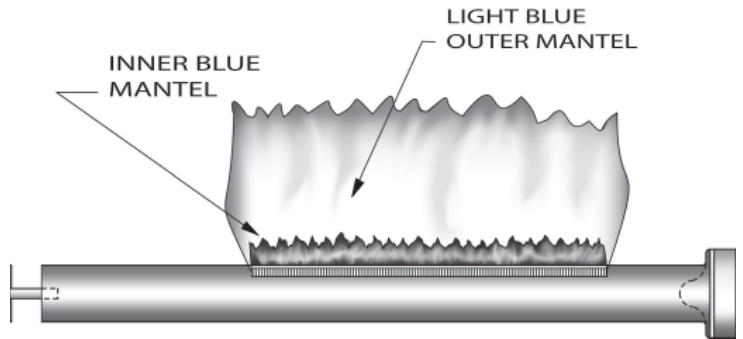

Figure 18 - Burner

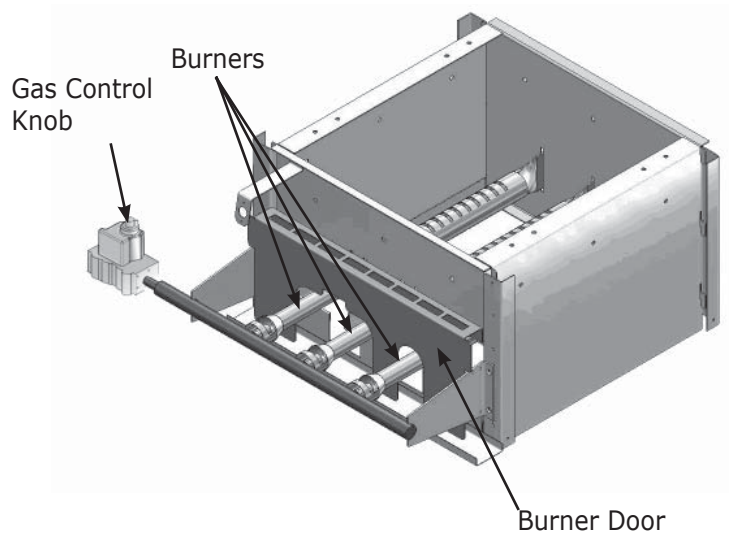
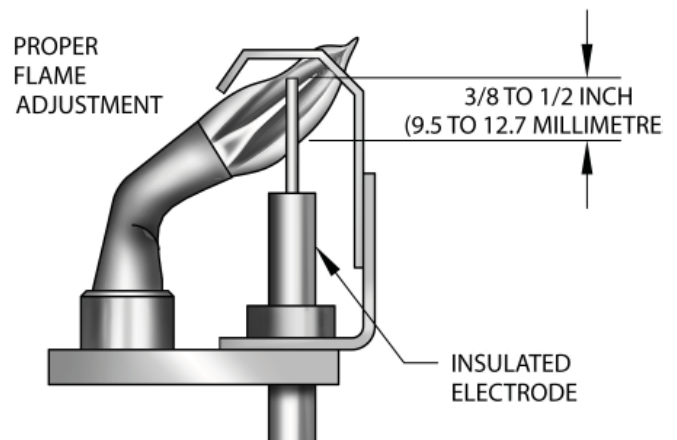



Figure 19 - Pilot Flame



15 - CHECKING GAS INPUT RATE TO BOILER

Gas input to boiler can be adjusted by removing protective cap on pressure regulator **Figure 18, Page 23** and turning screw clockwise  to increase input and counterclockwise  to decrease input. Manifold pressures are taken at outlet side of gas valve. See Figure 12, Page 18. To check for proper flow of natural gas to boiler, divide input rate shown on rating plate by heating value of gas obtained from local gas company. This will determine number of cubic feet of gas required per hour. With all other gas appliances off, determine flow of gas through meter for two minutes and multiply by 30 to get hourly rate. Make minor adjustments to gas input as described above.

Burner orifices should be changed if final manifold pressure varies more than plus or minus 0.3 inches water column from specified pressure.

Primary air adjustment is not necessary, therefore air shutters are not furnished as standard equipment. Air shutters can be furnished on request where required by local codes or conditions.

CHECK SAFETY CONTROL CIRCUIT. Ignition system safety shutoff device must be tested after placing boiler in operation.

Intermittent Pilot: With main burner operating, turn pilot gas adjusting screw clockwise  until pilot gas is turned off. See Figure 15, Page 21 Within 90 seconds main gas control should close, shutting off gas to main burner.

High Limit Control (Figure 23): Remove cover and note temperature setting. Decrease this setting to minimum and operate boiler. When boiler water temperature exceeds control temperature setting, control will open circuit, closing automatic main gas valve.

Figure 20 - Boiler Right Side and Front

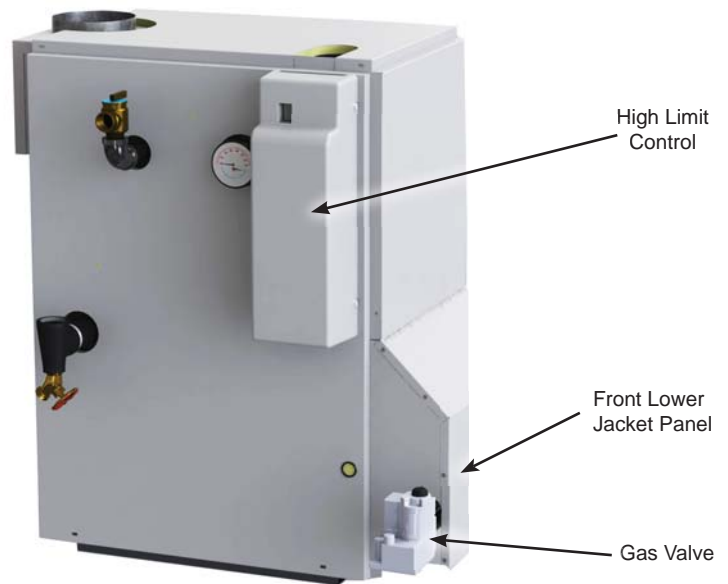

A.1 Installation Environment Considerations

⚠ WARNING

If you do not follow these instructions exactly, a fire or explosion may result causing property damage, personal injury or loss of life.

- **Do not use this appliance if any part has been under water.** Immediately call a qualified service technician to inspect appliance and to replace any part of control system and any gas control which has been under water.
- Do not allow water to drip on controls. Prevent condensation by allowing air circulation around module and gas control.
- Do not use corrosive chemicals around or on module or gas control.

- Controls can be damaged by excessively high temperatures. Verify adequate air circulation around control is maintained when installing boiler.

A.2 Electrical Connections

Connect Module Connectors Figure 14, Page 20

- L1& L2 leads inside J box using wire nuts. Secure J box cover.
- Circulator harness to circulator. Harness comes plugged into module with Molex[®] plug.
- Thermostat connection to yellow wires marked TT using wire nuts.
- Ensure remaining Molex[®] plug connectors have not worked loose during transit.
- Check sensing bulb is fully inserted in well and is not loose.
- Refer to enclosed addendum for wiring instructions when using indirect hot water heater.

A.3 Adjusting Settings

To discourage unauthorized changing of settings, procedure to enter adjustment mode is required.

To enter adjustment mode, press UP, DOWN, and I buttons simultaneously for three seconds. Press and release I button until parameter requiring adjustment is displayed. See Figure 12, page 18.

- "SP_" Setpoint (180 °F default setting; adjustable between 130 and 220 °F)
- "Df_" Setpoint Differential (15 °F default setting; adjustable between 10 and 30 °F)
- "°F_" Degrees Fahrenheit

Press UP or DOWN button until parameter has reached desired value. After 60 seconds without any button inputs, control automatically returns to READ mode.

A.4 Display

In RUN mode, status items and parameters are viewable.

Example, to display setpoint, control flashes "sp" (setpoint) followed by temperature (i.e., 135), followed by °F or °C.

To read settings, press and release I key to find parameter of interest.

Example, press and release I until setpoint (sp) is displayed, followed by three-digit number, i.e., 190, followed by °F or °C. Press I button again will display (S1T) Sensor 1 Temperature followed by three-digit number and corresponding degree designator.

See Display Readout.

Figure 21 - Display Readout

Text	Description	Display Shows
sta	Current State	StA
s1t	Sensor 1 Temperature	S1t
sp	Setpoint	SP
dff	Setpoint Differential	dFF
hr	Heat Request Status	hr
err	Error Code	Err
fla	Flame Current	FLA
°F	Degrees Fahrenheit	°F
°C	Degrees Celsius	°C
uA	Micro Amps	uA

APPENDIX A - CONTROL MODULE

A.5 Operation

Module continuously monitors boiler water temperature and fires or shuts off burner based on this temperature data.

1. When "Call for Heat" occurs, control enables circulator and monitors boiler water temperature to determine whether thermostat can be satisfied without firing burners.
2. Control determines burner operation is required, module proceeds to start burner (see state codes list) and heats water in boiler until setpoint temperature is achieved or thermostat is satisfied. .
3. Burner is de-activated, ignition module completes heating cycle, returns to idle and waits for temperature to drop again.
4. Circulator is turned on throughout "Call for Heat."

Table 6 - Operation State Codes

State Code Number	Definition	Explanation
1	Idle	Standby - no call for heat
	Circulator	Heat request present. Boiler temperature sufficiently high to run circulator pump only.
4	Pre-purge	System is purging before ignition trial; includes Pilot Valve circuit diagnostics.
6	Spark	System sparking. Flame is not present up to 13 seconds
7	Flame stabilization	Flame signal is being established. Variation in signal is allowed during this state, flame must be stable at end of period
8	Running	System is running. Flame signal must be present.
9	Post-Purge	System is purging at end of call for heat
10	Retry Recycle Delay	Successful ignition was not detected, and delay is called before retry.
		Flame signal was lost during state 7 or 8, and delay is called before retry (32 second delay)
13	Soft lock-out	Soft lockout duration is one hour, may override with manual reset.
14	Hard lock-out	Manual reset is required for hard lockout
15	Wait for limit to close	Possible thermostat call for heat; limit switch is open.
16	Flame out of sequence	Flame signal sensed before trial for ignition. Appropriate alarm is sent. OR
		Flame signal sensed out of sequence during post purge. Appropriate alarm is sent. OR
		Flame signal present when not expected. Appropriate alarm is sent.
17	Pilot valve diagnostics	Pilot valve circuitry diagnostics during pre-purge.
	Current leakage detection	Self check performed at start up, again at beginning of heat cycle, and during "Wait for Recovery " State.
	Wait for recovery	Self check performed at start up, again at beginning of heat cycle, and during "Wait for Recovery " State
18	Wait for damper to open	Control has signaled damper/pressure switch to close, and is waiting for completion. If damper/pressure switch does not close within 60 seconds, control goes to State 20.
19	Wait for damper to close	Damper is closed and control waits for damper to open. Checked at beginning of heat cycle before opening damper. If damper does not open in 60 seconds, control goes to State 21.
20	Wait for damper to open (Failed close)	Damper has not opened (end switch not closed) at beginning of heat cycle. Alarm message is sent, control is NOT in lockout.
21	Wait for damper to close (Failed open)	Damper has not closed despite actuator de-energized. Alarm message is sent, control is NOT in lockout.

A.6 Boiler High Limit Temperature Controller

- When water temperature reaches setpoint, controller ends heating cycle.
- When water temperature drops below setpoint minus differential, controller restarts heat cycle to re-heat boiler water.
- If water temperature exceeds maximum allowed temperature (220°F or 104°C), controller enters manual reset lockout state.
- For manual reset press any onboard button or cycle power to reset.

A.7 Troubleshooting

- Following service procedures are provided as general guide.
- On lockout and retry models, meter readings between gas control and ignition module must be taken within trial for ignition period. Once ignition module shuts off, lockout models must be reset through key buttons and display. On retry models, wait for retry or reset at thermostat.
- Check for correct installation and wiring before replacing any component.
- Control module cannot be repaired. If it malfunctions, it must be replaced.
- Use only qualified service agent to service ignition systems.

Figure 22 - Basic Control Algorithm Example

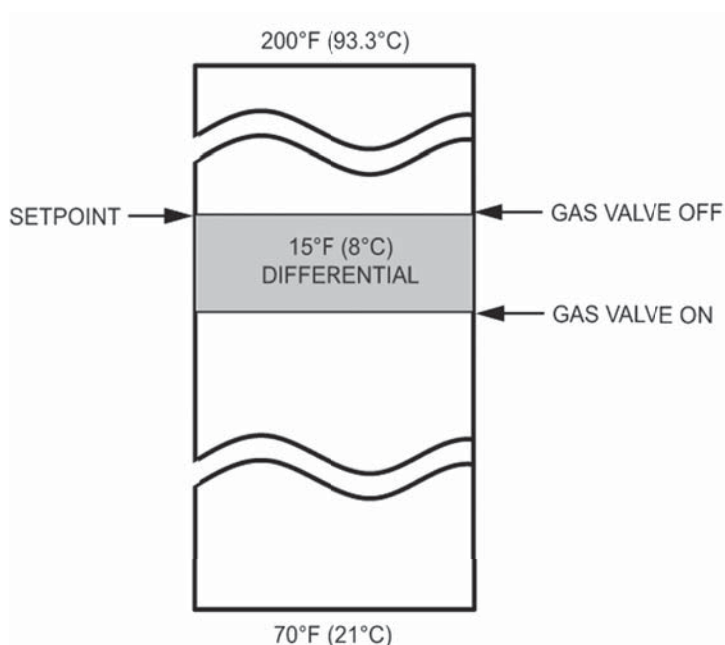

1. Perform checkout as first step in troubleshooting.
2. Check troubleshooting guide to pinpoint cause of problem. See Table 7, page 35.
3. If troubleshooting indicates ignition problem, see Ignition System Checks to isolate and correct the problem.
4. Perform checkout procedure following troubleshooting guide again to verify system is operating normally.

A.8 Troubleshooting Error Codes

Integrated boiler control uses advanced diagnostic capability to assist in troubleshooting error conditions. Table 7 shows codes that could arise on integrated display during fault. Suggestions are provided in Table 7 for servicing these potential errors.

Table 7 - Troubleshooting Error Codes

Error Code Number	Definition	Consequence
4	Flame current too low. Check for flame.	Non critical alarm
6	Flame sensed out of normal sequence (before opening or after closing gas valve).	Soft lockout
18	Gas valve relays welded. Five consecutive soft lockouts.	Hard lockout
23	Flame sensed during prepurge (before gas valve signaled opened).	Soft lockout
32	Sensor 1 error. Temperature sensor in well is not reading correctly. Verify it is connected to board. Replace if necessary.	Wait for recovery
55	Atmospheric damper end switch failed to close (end switch contacts stuck open).	Wait for recovery
56	Atmospheric damper end switch failed to open (end switch contacts stuck close).	Wait for recovery
57	Igniter flame rod shorted to burner ground	Wait for recovery
58	Igniter flame rod shorted to burner ground. Repair or replace igniter.	Wait for recovery
59	Line Voltage error - voltage out of specification high or low (15-37V (44-66Hz))	Wait for recovery
60	Applies only to thermostats having on-board transformer. Polarity is wrong in this case.	Wait for recovery
	Thermostat input higher than threshold.	
61	Line voltage unstable - possibly too may heavy loads switching on and off causing erratic supply voltage.	Wait for recovery
62	Soft lockout: maximum number of retries exceeded.	Soft lockout
	Soft lockout is reset after one hour if alarm reason disappears.	
63	Soft lockout: maximum number of recycles exceeded.	Soft lockout
64	Soft Lockout - electronics failure. On-board self diagnostics detected error.	Soft lockout
65	Over temperature error. Sensor measured temperature in excess of maximum allowable limit.	Soft lockout

Note: Soft lockout time is 1 hour or manual reset. Hard lockout requires manual reset.

A.9 Intermittent Ignition System Verification

STEP 1: Check ignition cable.

- Verify ignition cable does not run in contact with metal surfaces.
- Verify only factory supplied Ignition cable (or approved replacement) is used.
- Verify connections to ignition module and igniter or igniter-sensor are clean and tight.
- Verify ignition cable provides good electrical continuity.

STEP 2:

Verify ignition system grounding. Nuisance shutdowns are often caused poor or erratic grounding.

Common ground is required for module and pilot burner/igniter sensor.

- Check for good metal-to-metal contact between pilot burner bracket and the main burner.
- Check ground lead from GND (BURNER) terminal on module to pilot burner. Verify connections are clean and tight. If wire is damaged or deteriorated, replace with No. 14-18 gauge, moisture-resistant, thermoplastic insulated wire with 105°C [221°F] minimum rating.
- Check ceramic flame rod insulator for cracks or evidence of exposure to extreme heat, which can permit leakage to ground. Replace pilot burner/igniter sensor and provide shield if necessary.
- If flame rod or bracket is bent out of position, restore to correct position.

STEP 3: Check spark ignition circuit.

Disconnect ignition cable at SPARK terminal on module.

 WARNING
<p>Electrical shock hazard. Ignition circuit generates over 10,000 volts. Turn OFF electrical power supply at service panel before making electrical connections. Failure to do so could result in death or serious injury.</p>





Energize module and listen for audible sparking noise. When operating normally, there should be buzzing noise turns on and off twice per second for duration of 1–7 seconds, depending on model.

STEP 4: Verify pilot and main burner lightoff.

- Initiate call for heat. Turn thermostat above room temperature. Ignition sequence may be delayed by thermal purge until boiler water temperature is below 140°F (60°C)
- Watch pilot burner during ignition sequence.
 - Verify ignition spark continues after pilot is lit.
 - Verify pilot lights and spark stops, verify main burner does not light.
- If so, ensure adequate flame current as follows.
 - Turn off boiler at circuit breaker or fuse box.
 - Clean flame rod with emery cloth.
 - Verify electrical connections are clean and tight. Replace damaged wire..
 - Check for cracked ceramic insulator, which can cause short to ground, and replace igniter-sensor if necessary.
 - At gas valve, disconnect main valve wire from MV terminal.
 - Turn on power and set thermostat to call for heat. Pilot should light, main burner will remain off because main valve actuator is disconnected.
 - Check pilot flame. Verify it is blue, steady and envelops 3/8 to 1/2 in. [10 to 13 mm] of flame rod. Figure 23 for possible flame problems and causes.
 - If necessary, adjust pilot flame by turning pilot adjustment screw on gas control clockwise to decrease or counterclockwise to increase pilot flame. Following adjustment, always replace pilot adjustment cover screw and tighten firmly to assure proper gas control operation. Figure 15, Page 21.
 - Set temperature below room set-point to end call for heat.

- Recheck ignition sequence as follows.
 - Reconnect main valve wire.
 - Adjust thermostat above room temperature.
 - Verify ignition sequence at burner.
 - If spark does not stop after pilot lights, replace module.
 - If main burner does not light or if main burner lights and system locks out, check module, ground wire and gas control as described in troubleshooting table. See Table 9, Page 35.

Figure 23 - Pilot Flame

APPEARANCE	CAUSE
<p>SMALL BLUE FLAME</p> 	<p>CHECK FOR LACK OF GAS FROM:</p> <ul style="list-style-type: none"> • CLOGGED ORIFICE FILTER • CLOGGED PILOT FILTER • LOW GAS SUPPLY PRESSURE • PILOT ADJUSTMENT AT MINIMUM
<p>LAZY YELLOW FLAME</p> 	<p>CHECK FOR LACK OF AIR FROM:</p> <ul style="list-style-type: none"> • DIRTY ORIFICE • DIRTY LINT SCREEN, IF USED • DIRTY PRIMARY AIR OPENING, IF THERE IS ONE • PILOT ADJUSTMENT AT MINIMUM
<p>WAVING BLUE FLAME</p> 	<p>CHECK FOR:</p> <ul style="list-style-type: none"> • EXCESSIVE DRAFT AT PILOT LOCATION • RECIRCULATING PRODUCTS OF COMBUSTION
<p>NOISY LIFTING BLOWING FLAME</p> 	<p>CHECK FOR:</p> <ul style="list-style-type: none"> • HIGH GAS PRESSURE
<p>HARD SHARP FLAME</p> 	<p>THIS FLAME IS CHARACTERISTIC OF MANUFACTURED GAS</p> <p>CHECK FOR:</p> <ul style="list-style-type: none"> • HIGH GAS PRESSURE • ORIFICE TOO SMALL

Correct Pilot Flame: 3/8 to 1/2 inch in flame. See Figure 19, Page 23.



PENNCO BOILERS
2201 Dwyer Avenue, Utica NY 13501
web site: www.ecrinternational.com